

P-05X Specifications

Playable disc types	
Super Audio CD, CD, CD-R, CD-RW	
Digital output	
ES-LINK connectors	1 pair (L/R)
XLR connectors	1 pair (L/R) *During Dual AES connection, one connector each is used for the left and right channels (Lch and Rch).
RCA connector	1
Clock input	
BNC connector	1
Input impedance	50Ω
Frequencies that can be input	44.1kHz, 88.2kHz, 176.4kHz, 10MHz, 22.5792MHz (±10 ppm)
Input level	Rectangle wave
	Sine wave
equivalent to TTL levels	
0.5 to 1.0 Vrms	
General	
Power supply	AC 220-240V, 50/60Hz AC 120V, 60Hz AC 220V, 60Hz
Power consumption	16W
External dimensions (W x H x D, including protrusions)	445mm x 131mm x 359mm (17 5/8" x 5 1/4" x 14 1/4")
Weight	13.5kg (29 7/8 lb)
Included accessories	Power cord x 1, HDMI cable x 1, Remote control unit (RC-1301) x 1, Batteries for remote control (AAA) x 2, Felt pads x 3, Owner's manual x 1, Warranty card x 1

Super Audio CD Transport P-05X



34-bit Dual Mono D/A Converter D-05X



P-05X/D-05X

Master Clock Generator G-02X

D-05X Specifications

Analog audio outputs	
XLR connectors	1 pair (L/R)
RCA connectors	1 pair (L/R)
Output impedance	XLR
	RCA
Maximum output level (when 1kHz, full-scale signal input, 10kΩ load)	XLR (when set to 0 dB)
	RCA
Frequency response (when 192kHz PCM signal input)	5Hz to 65kHz(-3dB)
S/N ratio	120dB (1kHz, A-weighted)
Distortion	0.0008% (1kHz)
Digital audio inputs	
ES-LINK connectors	1 pair (L/R)
Input signal format	Linear PCM (ES-LINK4)
	DSD (ES-LINK4)
XLR connectors	2 (Selectable: Dual AES x 1 or Single AES x 2)
	Input level
	Input impedance
	Input signal format (with Dual connection)
RCA connector	1
	Input level
	Input impedance
	Input signal format
Optical digital connector	1
	Input level
	Input signal format
	Input signal format (with Single connection)
USB port	1 (Type B)
	Input signal format
Clock output	
BNC connector	1
Output level	TTL level equivalent (into 75Ω)
Output frequencies	44.1kHz, 88.2kHz, 176.4kHz, 48kHz, 96kHz, 192kHz
	22.5792MHz, 24.576MHz
Output frequency precision	Same as input frequency (when set to through output)
Clock input	
BNC connector	1
Input impedance	50Ω
Frequencies that can be input	44.1kHz, 88.2kHz, 176.4kHz, 48kHz, 96kHz, 192kHz, 10MHz, 22.5792MHz, 24.576MHz (±10ppm)
Input level	TTL level equivalent
General	
Power supply	AC 220-240V, 50/60Hz AC 120V, 60Hz AC 220V, 60Hz
Power consumption	25W
External dimensions (W x H x D, including protrusions)	445mm x 131mm x 360mm (17 5/8" x 5 1/4" x 14 1/4")
Weight	14.0 kg (30 7/8 lb)
Included accessories	Power cord x 1, HDMI cable x 1, Felt pads x 3, Owner's manual x 1, Warranty card x 1

- These products are made available in three different power supply variations, as shown in the chart above. Make sure that the voltage shown on the rear panel matches the AC line voltage in your area.
- The shape of the AC inlet and plug of the supplied power cord depends on the voltage rating and destination country.
- Specifications and appearance are subject to change without notice.
- Weight and dimensions are approximate.

ESOTERIC

Super Audio CD Transport **P-05X**
34-bit Dual Mono D/A Converter **D-05X**



PROUDLY MADE IN TOKYO

ESOTERIC

ESOTERIC COMPANY

1-47 Ochiai, Tama-shi, Tokyo 206-8530, Japan
Fax: (042) 356-9240
www.esoteric.jp

Please note that Esoteric products are only available from approved distributors in overseas territories.
"ESOTERIC" and "VRDS" are trademarks of TEAC Corporation, registered in the U.S. and other countries.
"Grandioso" is a trademark of TEAC Corporation.
©2017 TEAC Corporation. All Rights Reserved. All text, images, graphics and other materials in this catalog are subject to copyright and other intellectual property rights of TEAC Corporation. These materials may not be directly or indirectly published, reproduced, modified or distributed in any medium.
"Super Audio CD" and "DSD" are registered trademarks.
Other company names and product names in this document are the trademarks or registered trademarks of their respective owners.
Design and specifications are subject to change without notice.

PRINTED IN JAPAN 0317005 TECD- 0252

A new milestone cultivated by 30 years of tradition

The lineage of high-end digital audio follows the evolutionary steps of ESOTERIC digital players.

This began with the first generation P-1/D-1 model in 1987,

which made the revolutionary step of including a VRDS mechanism,

and was followed by models featuring the ultimate in engineering and craftsmanship,

such as the P-70/D-70 in 2001 and the P-03/D-03 in 2005.

In the year 2016 these models were succeeded by the superior P-02X/D02X.

And now three decades after the birth of the ESOTERIC brand, we have the P-05X/D-05X.

The P-05X/D-05X inherits the successful results of the P-02X/D-02X to give birth to

a new milestone in high-end audio which is suitable for the start of the next three decades.



34-bit Dual Mono D/A Converter

D-05X



Super Audio CD Transport

P-05X

LEADING TECHNOLOGY

In the Footsteps of ESOTERIC's Most Advanced Grandioso Technology

ES-LINK4

Both the P-05X and D-05X have been newly equipped with ESOTERIC's state-of-the-art ES-LINK4, which provides high-accuracy digital transmission of both DSD and ultra-wideband 352.8kHz/48-bit PCM by way of its HDMI cable connections. A core feature of the Grandioso P1/D1 digital source system, and developed in line with ESOTERIC's 'Pure D/A' concept, ES-LINK4 performs the major portion of digital signal processing on the transmission side to significantly reduce the processing load on the D/A converter in pursuit of the ultimate in sound quality.

The Expressive Power of 34-bit D/A Processing

The D-05X utilizes a 34-bit D/A processing algorithm to convert the PCM signal to analog. This 34-bit encoding provides an astounding level of digital resolution that is fully 1,024 times that of 24-bit encoding, and quadruple that of the original D-05 model. Taking advantage of the delicate tone realized by this high-bit data minimizes calculation errors for outstanding expression of even the most subtle musical signals.

High-Precision VCXO Clock Technology

A high-precision custom VCXO (voltage controlled crystal oscillator) supplies a highly accurate reference clock signal to the digital circuitry. Incorporating an unusually large crystal element, this custom VCXO realizes both excellent center accuracy ($\pm 0.5\text{ppm}^*$) and extremely low levels of phase noise to ensure exceptional sound playback quality. (*at time of shipping)

High-Accuracy Clock Synchronization

A BNC cable connects the D-05X to the P-05X to provide a master clock sync signal for synchronized playback with minimized jitter. ESOTERIC's proprietary Direct Master Clock Link* synchronizes the two units while eliminating the need for Phase-Locked Loop (PLL), enabling clear and accurate stereo imaging and crisp sound quality. The system can be further upgraded with the addition of an optional high-accuracy external Master Clock Generator and supports a wide range of frequencies including master clocks (22MHz/10MHz) and word clocks (44.1kHz/88.2kHz/176.4kHz).

*DMCL (Direct Master Clock LINK)

DMCL links the D-05X to the P-05X with a 22.5792MHz reference clock signal that causes the two units to function as a single integrated device. Compared to normal 'sync' systems, which generally require PLL (Phase Lock Loop) processing of the transmitted clock signal, DMCL provides simpler and more direct clocking between multiple devices.

Super Audio CD Transport

P-05X

All major components updated from the original model to bring a new level of superiority

The P-05X is a brand new transport that brings together all the knowledge built up by ESOTERIC during the 10 years since the original P-05 model was released, and almost all of its components have been updated from the original model. This model includes the world-renowned VRDS-NEO VMK-5 drive mechanism and its digital circuit and clock circuit adopt technology developed for the Grandioso P1 and P-02X. The luxurious power supply circuit with large toroidal transformers has been enhanced to obtain even higher audio quality. Functionality has also been upgraded with support for ES-LINK4 digital transmission. By following the same design principles as higher end models, the chassis of the P-05X has been made more rigid and the exterior has evolved to emphasize an elegant round shape.

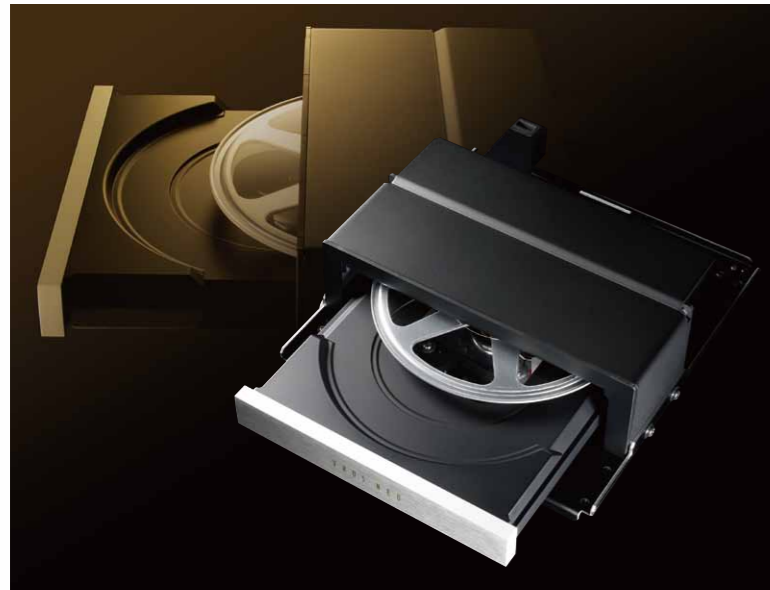

VRDS-NEO [VMK-5]

The unique VRDS-NEO VMK-5 transport mechanism featured in this new transport incorporates high-precision turntable that greatly improves reading accuracy by mechanically correcting for disc surface run-out. It's hybrid construction integrates precision-machined aluminum with polycarbonate to help minimize rotational inertia.

Formed of high-rigidity BMC (Bulk Molding Compound) and steel, the hybrid turntable bridge also makes a significant contribution to the suppression of rotational vibration and run-out. The transports spindle motor realizes further improvements in reading accuracy with an advanced servo control that uses rotation detection circuitry.

Mechanical operations such as opening and closing the tray and clamping the disc are performed by a unique differential gear system. This proprietary* Esoteric technology ensures exceptionally smooth disc loading operation.

* Patent No.2861798 owned by TEAC Corporation.

Axial Sliding Pick-up Designed to Prevent Optical Axis Tilting

The same axial sliding pick-up assembly, used in the flagship model Grandioso P1, is incorporated in the heart of the data acquisition section. As the lens moves, the laser optical axis is always positioned in a vertical direction, ensuring a highly accurate reading of the recorded material.

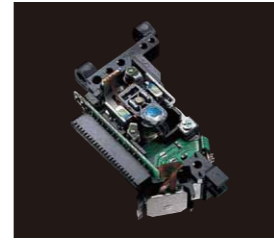

Elegantly Designed Robust Chassis

The exterior case is formed from thick aluminum panels, and its steel bottom plate is supported at three points on ESOTERIC's exclusive pinpoint feet. Vibration transmission has also been effectively minimized by the high-precision laser slot processing used in manufacture of its rigid base.



ES-LINK4

The ES-LINK4 is ESOTERIC's proprietary, super high speed, wide range, and extremely pure LVDS (Low Voltage Differential Signaling) digital interface. With this interface, most digital processing is done at the transport side and the three elements of the audio signal (audio data, LR clock, and bit clock signals) are separately transferred to the DAC in a differential mode, by utilizing the multi-conductor structure of the HDMI cable. Since the signal is already pre-processed at the transport side and is transferred without bi-phase modulation, a digital de-coding/oversampling process is not required on the signal receiver side. The DAC is simply dedicated to D to A processing and retrieves a purer analog signal from transferred digital streams.

A Selection of Digital Outputs

The P-05X has a pair of new ES-LINK4 HDMI ports, dual XLR connectors that maintain compatibility with earlier versions of ES-LINK, and a coaxial digital output.

Organic EL Displays

Both units feature smooth-operating, low-consumption electroluminescent (EL) displays that are eminently suited to such state-of-the-art components.



High-Quality Remote Control with a Luxurious Feel

The P-05X's RC-1301 Remote Controller is constructed from a solid aluminum top panel. The brushed finish on its control panel matches that of the unit's front panel and offers a luxurious feel of the highest quality.



34-bit Dual Mono D/A Converter

D-05X

A DAC following in the footsteps of the Grandioso D1, with uncompromising audio quality

The D-05X uncompromisingly inherits the DAC design philosophy of the Grandioso D1 flagship device and updates all the circuit components from the original D-05 model to obtain sound quality that should be considered the standard for ultra-high end devices. It includes a large capacitance power supply with two large toroidal transformers at the core for independent left and right channels. The circuit size of the DAC has been doubled to have four differential circuits per channel. In terms of functionality, the D-05X features ES-LINK4 digital transmission, 34-bit D/A processing, the well-received ESOTERIC-HCLD line buffer from the Grandioso C1 preamp, and the unique ES-LINK Analog line transmission for high audio quality. It also supports playback at high resolutions such as DSD 22.5 MHz to obtain even more outstanding audio playback overall.

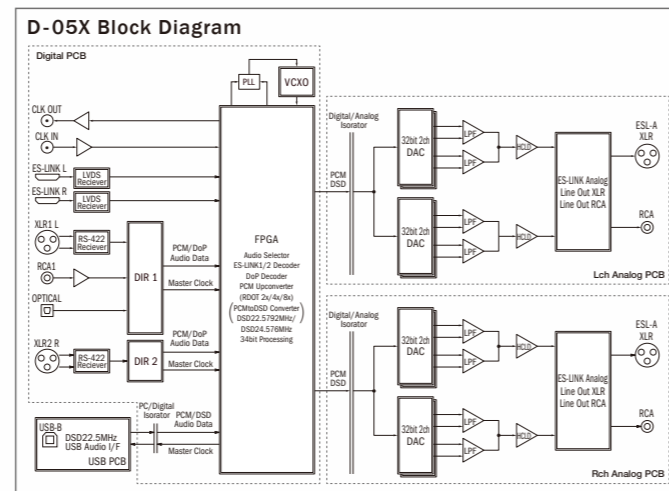
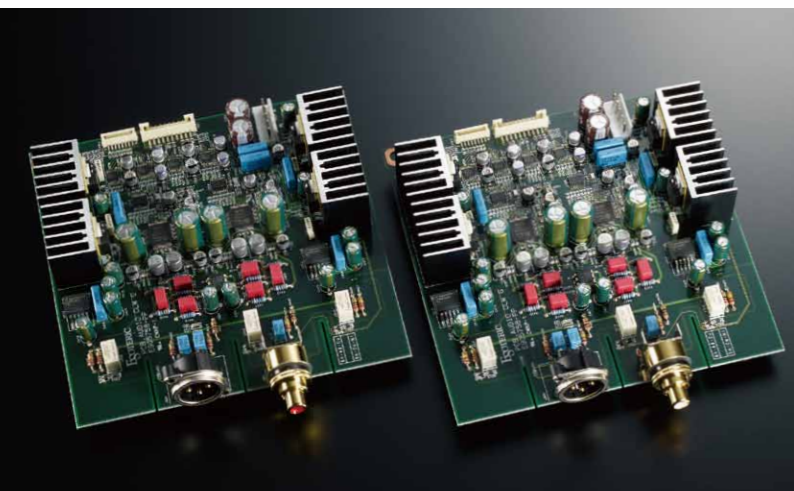

34-bit Resolution Accentuates the Most Delicate Sound Textures

The D-05X uses 8 (4 + 4) DAC circuits to achieve its low-noise and phenomenal linearity. Its AK4497 chipsets are produced by Asahi Kasei Microdevices. In addition to directly processing DSD signals, a new 34-bit D/A processing algorithm performs analog conversion of the PCM signal at 34-bit resolution for smooth, delicately detailed high-resolution sound quality.

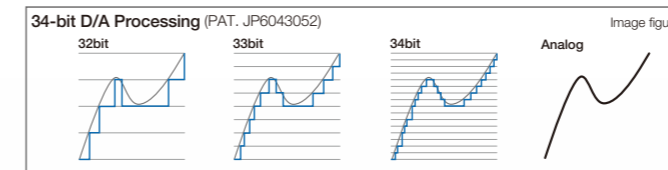

ESOTERIC-HCLD*: ESOTERIC's Exclusive Output Buffer Delivers Powerful Direct Current Transmission

The ability to produce comparatively large currents and high slew rates are two of the most important factors that enable an analog output circuit to accurately transmit the wide dynamic range of a music signal without degradation. The D-05X offers the ultimate performance as a line driver by adopting high-performance elements with a high current output and exceptionally fast slew rate (2,000V/μs) for excellent response speed. Two of these buffer circuits are employed per channel. By configuring them differentially to drive the XLR outputs and in parallel to drive the RCA outputs, the instantaneous output current available is maximized. By maximizing instantaneous current output, the D-05X reproduces the full dynamics of music with breathtaking realism.

*HCLD=High Current Line Driver

"ES-LINK Analog" Method for High Quality Current Transmission

In addition to regular line connections (XLR and RCA), the D-05X features the new "ES-LINK Analog" transmission method developed by ESOTERIC.

This is a current transmission signaling that utilizes the high performance of the HCLD buffer circuit and its enhanced ability to supply current at high-speed. This is the ideal analog audio transmission as it is free from impedance of signal route, thus fully maximizes the system's potential when connected to a compatible device.*

*Included in the Grandioso F1 as of March 2017. A standard balance cable (with an XLR terminal) is used for connections, but the "ES-LINK Analog" method can only be used with compatible devices since it is a proprietary transmission method.

Wide-Range D/D Conversion Compatible with Many Sources

In addition to playback at a source's original sampling frequency, the D-05X also features PCM up-conversion capability (2x, 4x, 8x) and PCM-to-DSD conversion that uses a proprietary algorithm to convert the PCM signal to fixed 22.5MHz DSD, enabling significantly smoother musical reproduction.

Digital Inputs Support High Sampling Rates

The D-05X's coaxial and optical inputs support PCM signals up to 24-bit/192kHz and 2.8MHz DSD (DoP). Two XLR inputs support 48-bit/192kHz (ES-LINK3), 24-bit/384kHz (Dual AES 8Fs) and 5.6MHz DSD (DoP Dual XLR mode).

USB Support for 22.5MHz DSD, 768kHz/32-bit PCM, and Asynchronous Transmission

The D-05X includes a USB terminal for connecting to computers, and the driver and "ESOTERIC HR Audio Player" playback software can be downloaded from the ESOTERIC website free-of-charge. The D-05X supports asynchronous transmission and playback at high sampling rates up to 22.5 MHz DSD and 768 KHz/32-bit PCM studio-master-quality source files.

Changeable XLR Output Pin Assignment

As phase can be digitally inverted in a contactless system, either Hot 2 or Hot 3 can be selected with no deterioration in sound quality.

